

- ① HOUSING MATERIAL: THERMOPLASTIC.
- ② CONTACT MATERIAL: COPPER ALLOY.
- ③ CONTACT FINISH: .00127-.00254 [.000050-.000100] NICKEL UNDERPLATE ALL OVER; .00076 [.000030] GOLD PLATE IN CONTACT AREA, TIN PLATED SOLDER TAILS.
- ④ SOLDER TAILS MUST FIT HOLE PATTERN AS SHOWN ON THE RECOMMENDED P.C. BOARD LAYOUT.
- ⑤ QUANTITIES OF VOID CORING ARE DEPENDENT ON THE POSITION SIZE OF THE HOUSING.
- ⑥ HOUSINGS WITH CENTER MOUNTING ARE RECOMMENDED FOR ASSEMBLIES HAVING 75 CONTACTS OR MORE PER ROW..

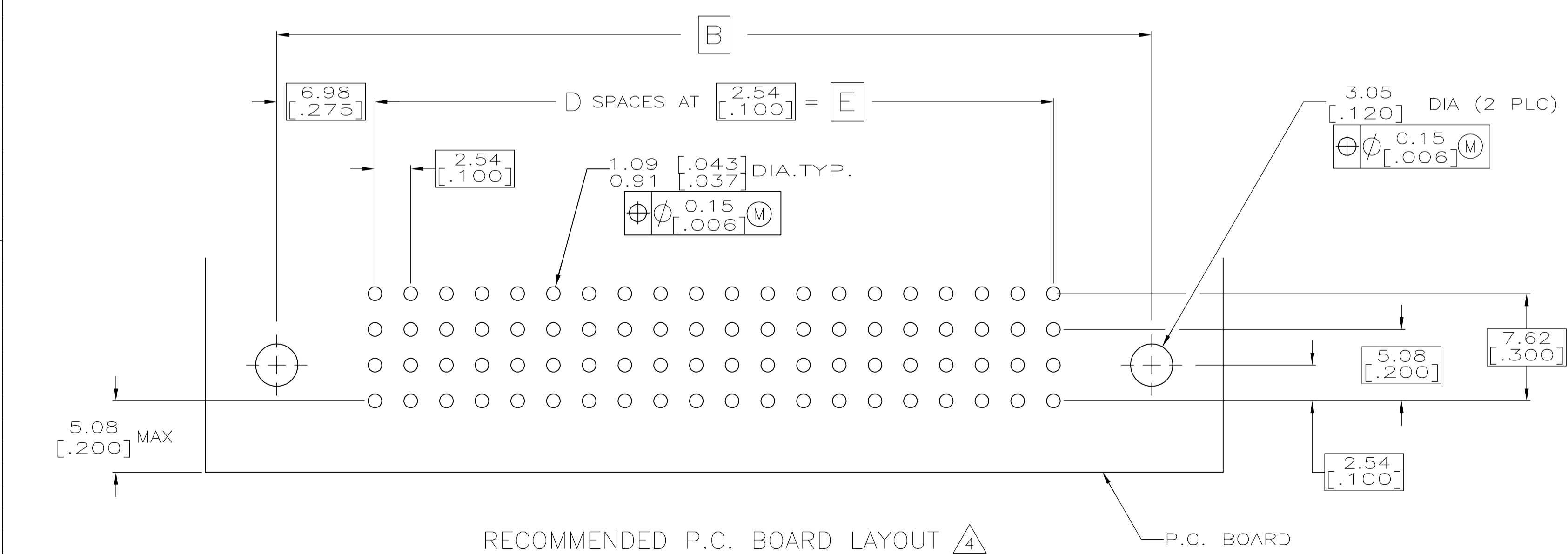
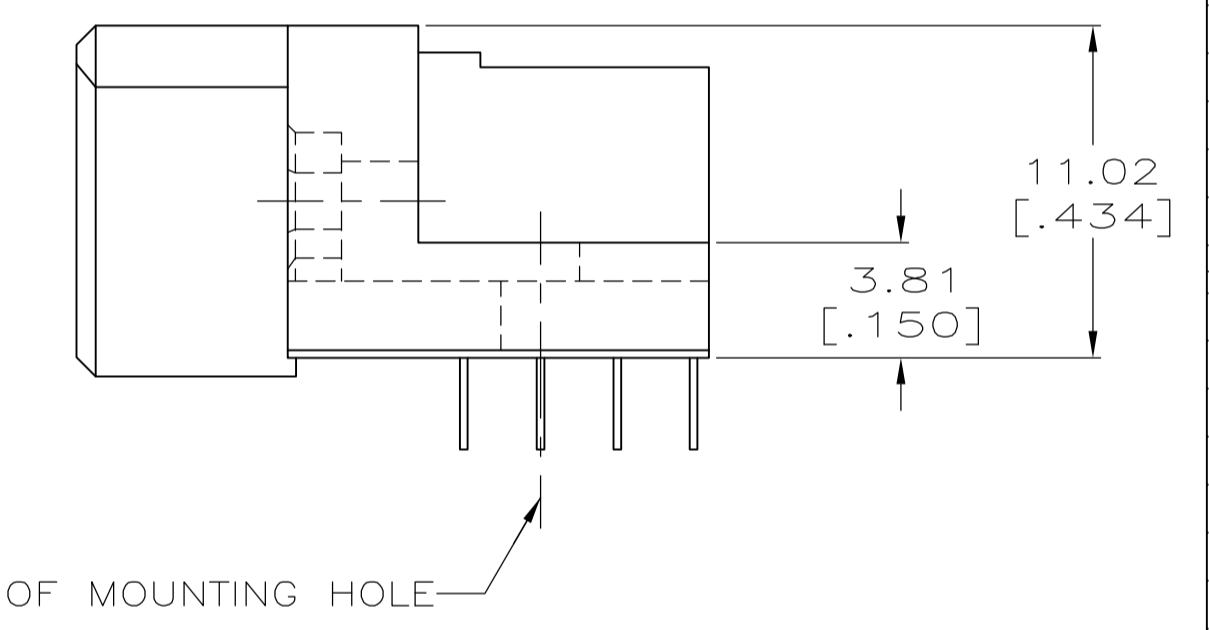
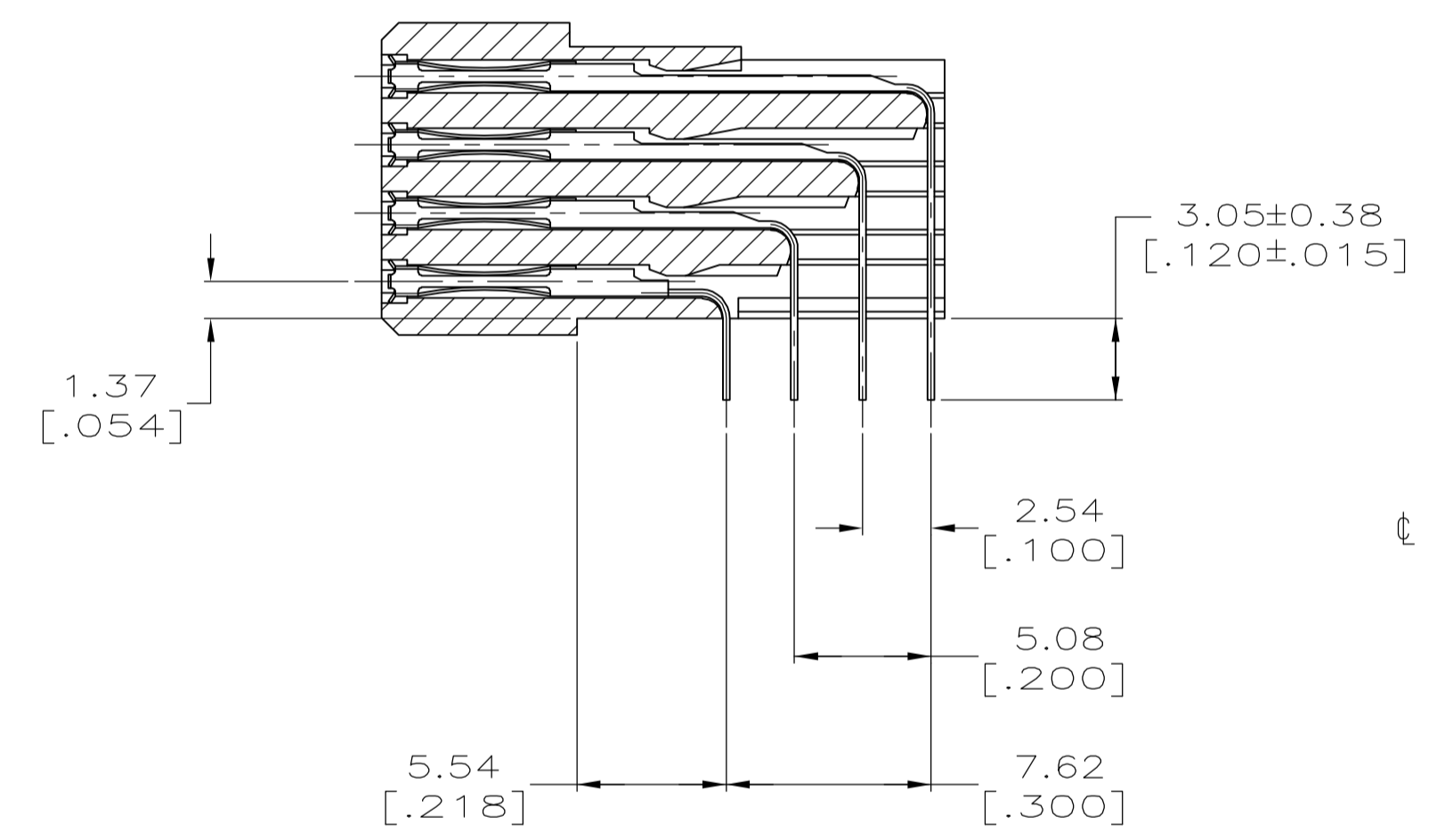
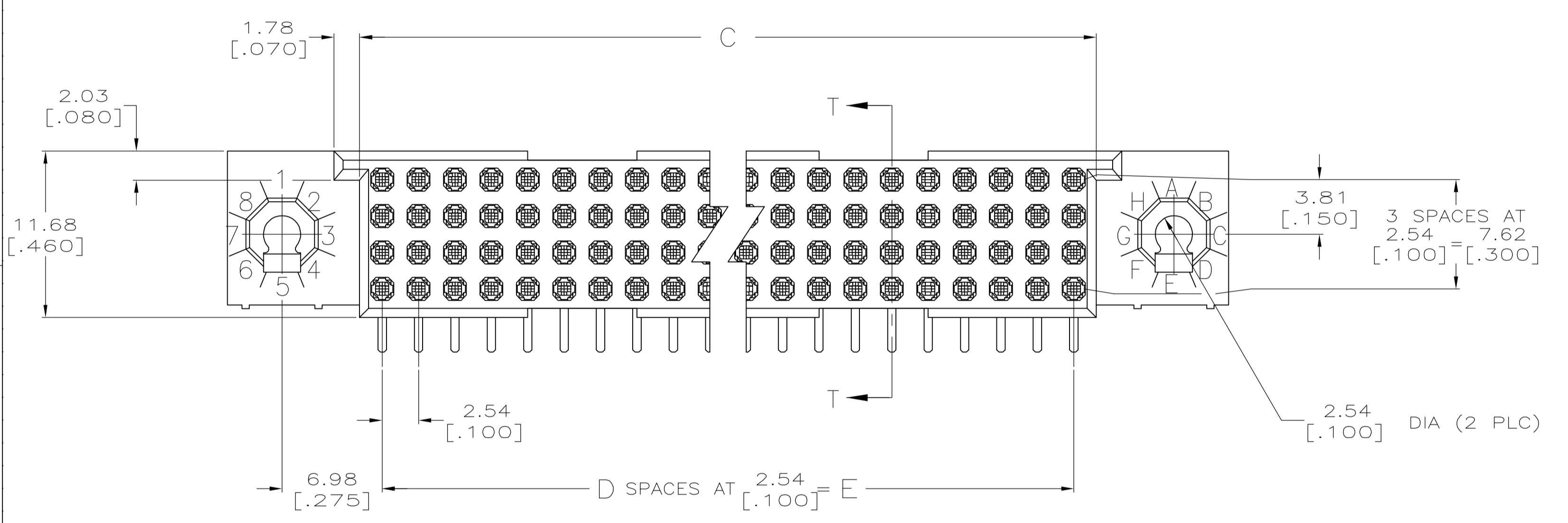

SECTION T-T

73.66 [2.900]	29	76.81 [3.024]	87.63 [3.450]	95.25 [3.750]	120	1-5532903-2
175.26 [6.900]	69	178.41 [7.024]	189.23 [7.450]	196.85 [7.750]	280	1-5532903-1
137.16 [5.400]	54	140.31 [5.524]	151.13 [5.950]	158.75 [6.250]	220	5532903-8
124.46 [4.900]	49	127.61 [5.024]	138.43 [5.450]	146.05 [5.750]	200	5532903-7
111.76 [4.400]	44	114.91 [4.524]	125.73 [4.950]	133.35 [5.250]	180	5532903-6
99.06 [3.900]	39	102.21 [4.024]	113.03 [4.450]	120.65 [4.750]	160	5532903-5
86.36 [3.400]	34	89.51 [3.524]	100.33 [3.950]	107.95 [4.250]	140	5532903-4
78.74 [3.100]	31	81.89 [3.224]	92.71 [3.650]	100.33 [3.950]	128	5532903-3
60.96 [2.400]	24	64.11 [2.524]	74.93 [2.950]	82.55 [3.250]	100	5532903-2
187.96 [7.400]	74	191.11 [7.524]	201.93 [7.950]	209.55 [8.250]	300	5532903-1
E	D	C	B	A	POSN	PART NUMBER

THIS DRAWING IS A CONTROLLED DOCUMENT. DWN: J. POLIGNONE 10JUN05. GJK: A. SHARPE 10JUN05. PRODUCT SPEC: A. SHARPE 10JUN05. NAME: ASSEMBLY, RECEPTACLE, RIGHT ANGLE, HDI, LEAD-FREE, 4 ROW, WITHOUT GUIDES, 3.05[.120] SOLDER POSTS.

MATERIAL: ①②③. FINISH: ③. WEIGHT: -. SIZE: A1. CAGE CODE: 00779. DRAWING NO: 5532903. RESTRICTED TO: -. CUSTOMER DRAWING. SCALE: 4:1. SHEET: 1 OF 1. REV: 0.